

REQUEST FOR PROPOSAL



BURLINGTON ELECTRIC DEPARTMENT

585 Pine street
Burlington, VT 05401-4891
Phone: 802-865-7456

RFP #

003-25

DATE:

7/10/2024

REQUEST FOR QUOTATION

THIS IS AN INQUIRY,
NOT AN ORDER

PLEASE QUOTE PROMPTLY

ALL RFP'S RESPONSES ARE TO BE
UPLOADED TO OUR SECURE
WEB SITE USING YOUR UNIQUE LOGIN

DELIVERY REQUIRED BY: ASAP	QUOTATION DUE BY NLT 07/30/24 11:00am EST	REQUISITION NO:	DEPT: ENGINEERING
-------------------------------	--	-----------------	----------------------

QTY	DESCRIPTION						
2	Transformer Size (kVA):	Primary Voltage	Secondary Voltage	Description	Spec Impedance	BED Specification	Associated BED Standards
	100	13800 Grd Y/7970	240/120V	100KVA Single Phase, Liquid Filled, Compartmental-Type, Dead Front, Loop Feed Padmounted Transformer	1.50% - 2.35%	S0118	160601, 160602

Purchase Price Constant	Load Loss Factor (\$/Watt)	No Load Loss Factor (\$/Watt)
1.281	\$1.43	\$28.26

Loss Evaluation formula "First Cost Multiplier"

NAMEPLATE SHALL INDICATE NON-PCB

Quote both Amorphous & Steel Core... If not quoting one type please specify why!

(when order is placed approval drawings will be required but should not effect the delivery time)(XFRPAD00130) This must be on the data plate)

UNIT COST=\$ _____ DELIVERY= _____ WEEKS ARO

LOSS EVALUATION FORMULA APPLIES TO QUOTE & PURCHASE PRICE:

No load = (Avg) _____ (Max) _____ Load =(Avg) _____ (Max) _____ Total = (Avg) _____ (Max) _____

IMPEDANCE: _____ Bid will be evaluated on average values.

Please confirm freight is included in unit cost. It is **Y/N** (circle one quoted)

CERTIFIED TEST REPORTS SHALL BE emailed AT THE TIME OF SHIPMENT TO engineering@burlingtonelectric.com . PAYMENT OF THE ABOVE ITEM SHALL BE HELD UNTIL RECEIVED AND ACCEPTED BY B.E.D.

DELIVERY REQUIREMENT: SHIP FOB DESTINATION FREIGHT ALLOWED . Hours are 7:30 am to 2:30pm M-F

BED RESERVES THE RIGHT TO ACCEPT OR REJECT ANY OR ALL PROPOSALS RECEIVED IN RESPONSE TO THIS RFP OR TO TAKE OTHER ACTION CONSISTENT WITH THE BEST INTEREST OF BED. BED RESERVES THE RIGHT TO NEGOTIATE SEPARATELY WITH ANY SOURCE TO SERVE THE BEST INTEREST OF BED.

EXCEPTIONS TO THIS RFP SHALL BE SUBMITTED IN WRITING & ACCEPTED BY B.E.D. ON THE AWARDED P.O. TO BE BINDING. ALL SUBMITTED BIDS BECOME THE PROPERTY OF BURLINGTON ELECTRIC DEPARTMENT. AFTER THE AWARDING OF THE CONTRACT TO THE SUCCESSFUL BIDDER, ALL BIDS ARE OPEN FOR PUBLIC VIEWING

ALL PROPOSALS MUST BE SUBMITTED VIA THE SECURE WEB SITE. BED WILL NO LONGER ACCEPT FAXED BIDS, EMAIL OR MAILED. ALL RFQ'S MUST INCLUDE OUTLINE DRAWING SHOWING DIMENSIONS OF TRANSFORMER. IF ANY INFORMATION IS MISSING THE RFP WILL BE DEEMED INVALID AND WILL NOT BE EVALUATED

VENDOR MUST COMPLETE THIS INFORMATION

- SHIPMENT CAN BE MADE _____ DAYS FROM RECEIPT OF ORDER
- F.O.B. DESTINATION FREIGHT ALLOWED BURLINGTON ELECTRIC DEPT. DOCK.
- TERMS _____ DISCOUNT OF _____ % IF PAID NET _____ DAYS
- QUOTE VALID _____ DAYS

SIGNED _____ DATE: _____

TITLE: _____ COMPANY: _____

B.E.D. RESERVES THE RIGHT TO ACCEPT OR DECLINE ANY AND ALL BIDS. ALL BIDS BECOME THE PROPERTY OF BURLINGTON ELECTRIC DEPARTMENT

Paul Charbonneau

SUPERVISOR OF PURCHASING & INVENTORY

TO INQUIRE ON ABOVE QUOTE PLEASE CALL PURCHASING DEPARTMENT DIRECT AT:

PAUL CHARBONNEAU 865-7456
email: pcharbonneau@burlingtonelectric.com

REQUEST FOR PROPOSAL

The following is a minimum check list that must be included in the submittal of the above RFP.

If any of the information is missing it will make your RFP invalid and we will not be able to consider it for evaluation!!!

DID YOU INCLUDE THE FOLLOWING AT A MINIMUM ?

Unit Cost

Delivery time

No Load (avg) & (max)

Load (avg) & (max)

Total (avg) & (max)

Impedance (must be average values)

Is delivery included in the cost of the item? If not what is the cost for delivery
Drawings with dimension.

Did you quote both Amorphous core and Steel? If not why?

Include manufacturer information about corrosion protection (item 14e on material spec) and coating (item 5j on material spec).

All RFP's must be uploaded to our secure site using your unique login. We will only accept Word, Excel or PDF submissions. Once you have Uploaded your file you will get an email indicating that it was successful. All times are based on EST.

Paul Charbonneau

SUPERVISOR OF PURCHASING & INVENTORY

TO INQUIRE ON ABOVE QUOTE PLEASE CALL
PURCHASING DEPARTMENT DIRECT AT:

PAUL CHARBONNEAU 865-7456
email: pcharbonneau@burlingtonelectric.com



**BURLINGTON ELECTRIC DEPARTMENT (BED)
MATERIAL SPECIFICATION**

**Single Phase, Liquid Filled, Compartmental-Type, Dead Front, Loop Feed
Padmounted Transformer**

1) Scope:

- a) This specification covers the electrical characteristics and mechanical features of three phase, 60 Hz, mineral oil immersed, self-cooled, 65°C rise, padmounted, distribution transformers.
- b) All transformers shall be in accordance with the latest revision of each referenced industry standard (listed below), except as modified by this specification.

ANSI/IEEE C57.12.00	ANSI/IEEE C57.12.28	ANSI/IEEE C57.12.38
ANSI/IEEE C57.12.70	ANSI/IEEE C57.12.80	ANSI/IEEE C57.12.90
ANSI/IEEE C57.91	ANSI/IEEE 386	
<u>Western Underground Committee Guide 2.13</u>		

2) Ratings:

- a) The kVA rating shall be as specified on the purchase order.
- b) The nominal high voltage rating and the basic impulse insulation level (BIL) shall be the following:

13800 Grd Y/7970	95 kV BIL
------------------	-----------

- c) The nominal low voltage rating and the basic impulse insulation level shall be:

240 / 120	30 kV BIL
-----------	-----------

3) Impedance Voltage:

15 - 167 kVA	1.50% - 2.35%
--------------	---------------

4) Testing:

- a) All transformer testing shall comply with ANSI/IEEE C57.12.00 and ANSI/IEEE C57.12.90.
- b) All transformers shall be tested for no load losses (85°C), total losses (85°C), percent impedance (85°C) and exciting current (100% rated voltage). No load losses shall also be tested at 105% rated voltage.
- c) All transformers shall be subjected to a full wave voltage impulse.
- d) The manufacturer shall supply verification that the design has passed Short Circuit criteria per ANSI/IEEE C57.12.00 and ANSI/IEEE C57.12.90.
- e) Complete certified test reports, by serial number, shall be delivered to BED with the transformers. These reports must either be signed by an authorized individual at the factory, or be accompanied by a cover letter referring to purchase order number and signed by an agent authorized to conduct

transformer sales business for the manufacturer.

5) Construction:

- a) The manufacturer shall certify that the transformer and the oil are PCB free. This shall be indicated on the transformer nameplate.
- b) The nameplate shall be made of a corrosion resistant material and permanently marked meeting ANSI/IEEE C57.12.00.
- c) All neutral connections shall be through a fully insulated bushing grounded to the transformer tank by removable ground strap(s).
- d) All insulating paper used as layer insulation in transformer coils shall be bonded type, coated on both sides with a thermosetting adhesive and properly cured prior to impregnating with oil or the coils shall be wound with primary conductor containing a thermosetting adhesive that when properly cured will form an effective bond, both turn to turn and layer to layer.
- e) The transformer shall have an electrostatically applied (or equivalent process) protective coating. The coating shall be resistant to transformer oils and shall withstand a minimum 160 inch-pound impact per ASTM D2794. The coating shall meet or exceed all requirements of ANSI/IEEE C57.12.28. The color shall be olive green, Munsell No.7.0GY3.29/1.5.
- f) Lifting lugs for a balanced lift.
- g) Construction of the unit shall be such that it can be lifted, skidded, rolled or slid into place on the pad without disturbing the high or low voltage cables.
- i) The overall dimensions of the unit shall be such that it will fit on BED Standard 1606, Fiberglass Transformer Pad.

6) Electrical Compartment:

- a) The electrical compartment shall comply with Figure 3 of ANSI/IEEE C57.12.38.
- b) Access to the electrical compartment shall be provided by a lift-up hood.
- c) The electrical compartment hood shall be equipped with provisions for locking with a single padlock. Compartment security shall also include a recessed, stainless steel penta-head bolt, which is accessible only with the padlock removed.
- d) The hood shall open to provide a clear working space.

7) High Voltage Terminations:

- a) The high voltage terminations and equipment shall be dead-front and shall conform to all applicable ANSI/IEEE and IEEE standards.
- b) Primary bushings shall be a two-piece design with universal bushing wells and load break bushing well inserts, rated for 8.3 kV/14.4 kV. BED will provide the bushing well inserts.
- c) Bushing wells shall be externally clamped and field replaceable.

Material Specification	Single Phase, Liquid Filled, Compartmental-Type,	Approved: <i>Burlington Electric</i>
# S0118	Dead Front, Loop Feed, Padmounted Transformer	Date: 7/31/2023
Burlington Electric Department		Page 2 of 4

- d) Bushing well studs shall be field replaceable.
 - e) Provisions for an insulated bushing (parking stand) shall be included.
 - f) Two (2) 200 amp universal bushing wells (for loop feed) shall be provided.
- 8) Low Voltage Terminations:
- a) The low voltage bushings shall be molded epoxy (or approved equivalent).
 - b) The secondary terminals shall be externally removable four (4) hole spades in accordance with Figure 6(B) of ANSI/IEEE C57.12.38.
- 9) Over-current Protection:
- a) A loadbreak, BAY-O-NET type, oil immersed fuse shall be provided in series with an oil immersed, back-up current limiting fuse (CLF). The BAY-O-NET fuse element shall be externally replaceable with a distribution hot stick. Dual voltage units shall be capable of accepting both fuse sizes.
 - b) The BAY-O-NET fuse shall be current sensing, RTE type 353C, or equal.
 - c) The BAY-O-NET fuse size shall be per Table 4 of Cooper Power Systems publication 240-50.
 - d) The BAY-O-NET fuse and fuse holder must be interchangeable with RTE brand components.
 - e) The BAY-O-NET fuse assembly shall be equipped with a flapper valve and an oil drip shield to minimize oil spillage when the fuse is removed.
 - f) The back-up CLF shall be RTE type ELSP, or equal.
 - g) The back-up CLF shall be coordinated with the BAY-O-NET fuse, per Table 4 of Cooper Power Systems publication 240-50 and sized to melt only on internal transformer faults.
 - h) The back-up CLF shall be connected on the source side of the BAY-O-NET fuse.
- 10) If a dual voltage primary is specified by BED, the dual voltage switch shall be for de-energized operation only and shall have each position clearly labeled.
- 11) Taps:
- a) If specified by BED, full capacity taps shall be provided. Taps shall be connected to the primary winding.
 - b) The tap changer shall be for de-energized operation only. The tap changer shall be manually operable by means of a rotary dial (or switch) and shall have provisions for padlocking.
 - c) Each tap changer position shall be labeled. The tap setting must be clearly visible upon opening the cabinet door.
- 12) The transformer shall be equipped with the following accessories:
- a) Oil level / fill plug.

- b) Oil drain plug.
- c) A replaceable automatic pressure relief device designed to re-seal after operating.
- d) A means of manually venting tank pressure.
- e) ANSI/IEEE tank grounding provisions in the electrical compartment.

13) Information to be provided with quotation:

- a) Outline drawing of a typical unit, including a one-line diagram of the transformer.
- b) Average percent positive impedance, X/R and percent exciting current.
- c) Average and guaranteed maximum Total Load Losses.
- d) Average and guaranteed maximum No Load Losses.
- e) A description of the method used to minimize tank corrosion (design details or type of treatment).
- f) Warranty information and location of the nearest service shop, owned and operated by the manufacturer, which is capable of repairing all components of the transformer.

14) Information to be provided with Shipment of Transformer:

- a) Manufacturer shall provide BED with the final X/R and percent positive impedance

15) Exceptions:

16) Any exceptions to this specification shall be clearly documented when quoting. Exceptions must be specifically granted in writing by BED. Failure of BED to acknowledge exceptions when placing an order requires the manufacturer to comply with this specification if the order is accepted.

17) BED's loss evaluation formula applies to all bids.

18) Penalties:

Failure to meet quoted losses may result in a financial penalty being assessed the manufacturer. The penalty will be determined via BED's loss evaluation formula.

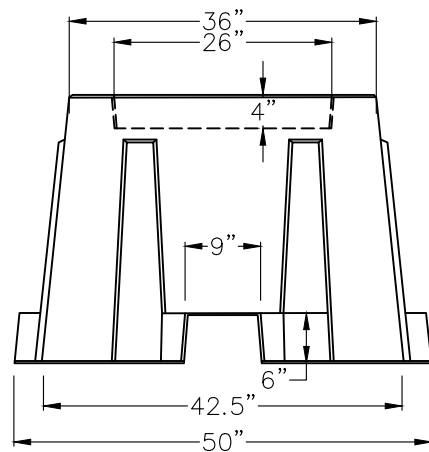
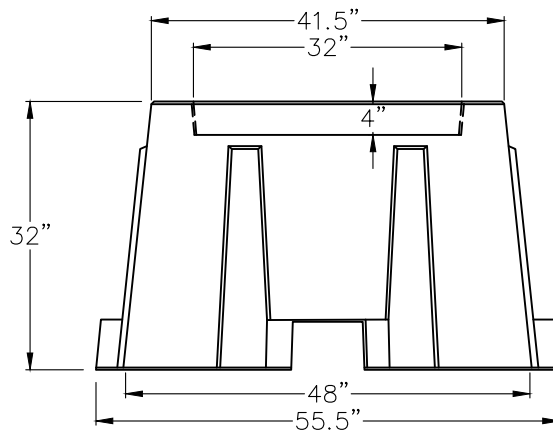
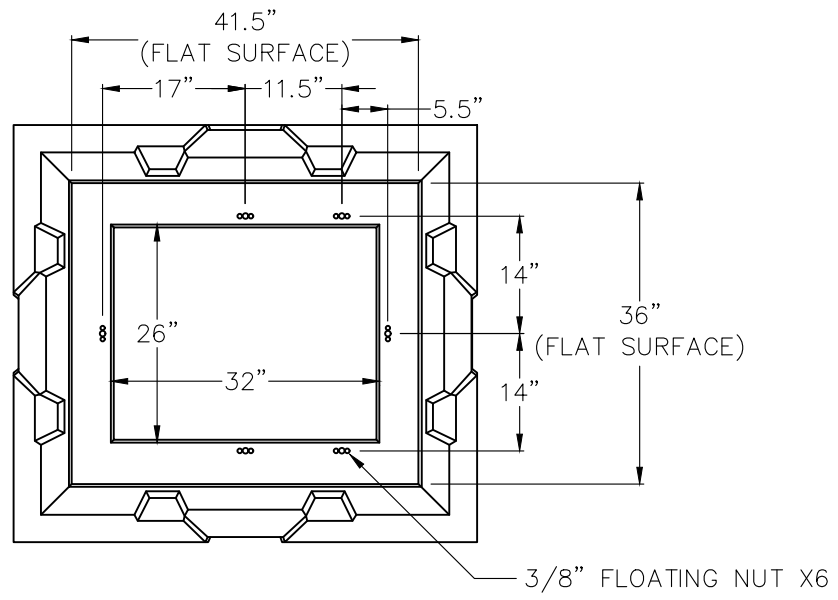

BURLINGTON ELECTRIC DEPT.	
DISTRIBUTION STANDARDS	
FIBERGLASS BOX SPECIFICATIONS AND INSTALLATION	
DATE: 06/24/19	DWG. NO.: 160601
DWN BY: RG	APP. BY:
SCALE: NONE	SHEET 1 OF 2

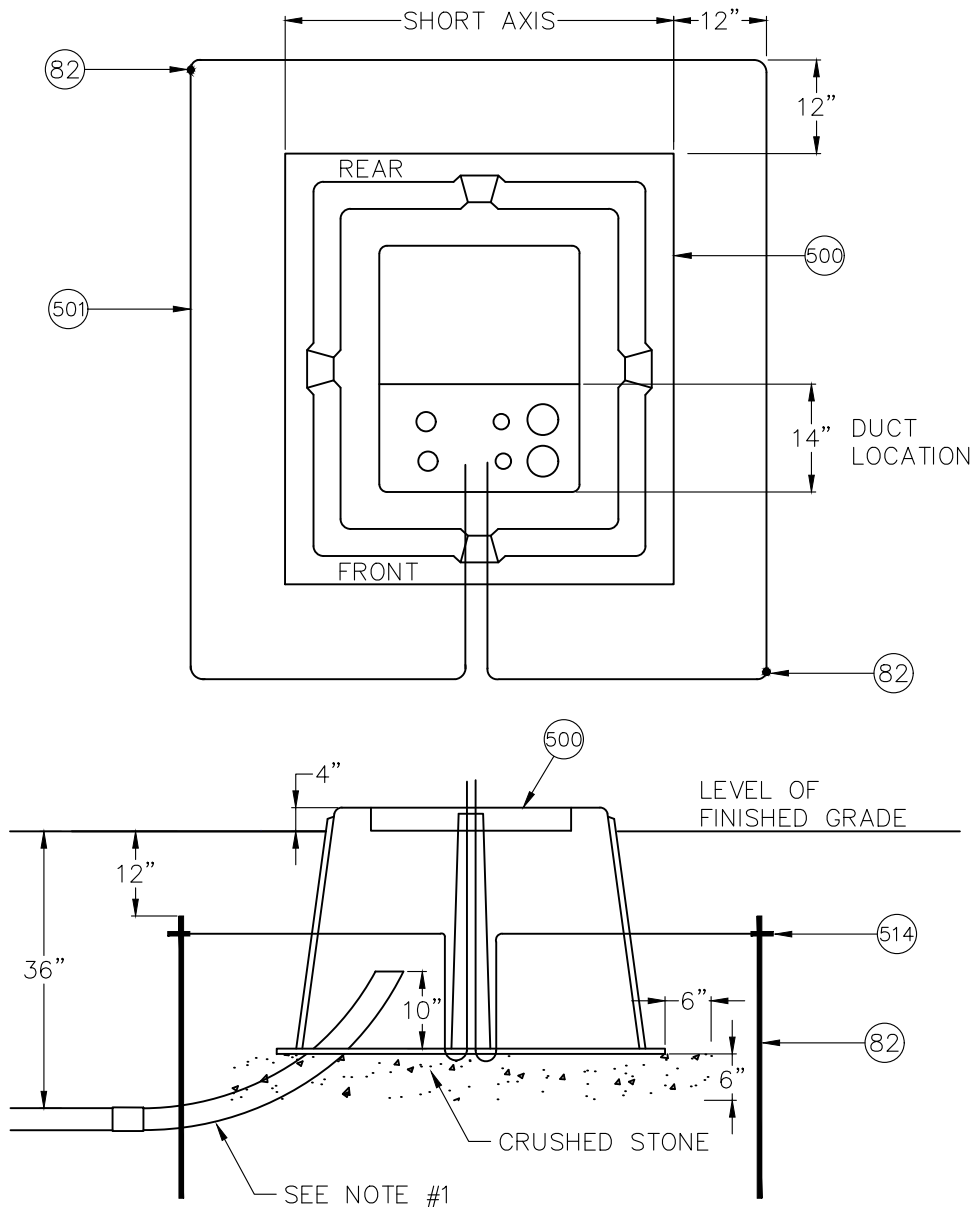

NOTES

1. 90° 36" RADIUS BEND MUST BE USED. SWEEP SHALL BE CUT OFF 10" ABOVE BOTTOM OF BOX.
2. A MINIMUM OF 6" CRUSHED STONE WILL BE PLACED UNDER BOX AND EXTEND 6" BEYOND THE PERIMETER OF BOX.
3. FINISHED GRADE SHALL BE A MINIMUM OF 4" BELOW TOP OF BOX.
4. BOXES USED FOR TRANSFORMERS OR TERMINATING POINTS SHALL HAVE A GROUND GRID INSTALLED.
5. CONDUITS WILL ENTER BOX IN THE FRONT 14" OF CLEAR OPENING.
6. FIBERGLASS BOX TO BE SUPPLIED BY BED AND INSTALLED BY CONTRACTORS.

BURLINGTON ELECTRIC DEPT.	
DISTRIBUTION STANDARDS	
FIBERGLASS BOX SPECIFICATIONS AND INSTALLATION	
DATE: 06/24/19	DWG. NO.: 160602
DWN BY: RG	APP. BY:
SCALE: NONE	SHEET 2 OF 2

TERMS and CONDITIONS

1. These Terms and Conditions, together with the purchase order and/or contract issued by the Burlington Electric Department's (B.E.D.) Purchasing Office, constitute the entire agreement between B.E.D. and the supplier/contractor. Any modification to said agreement shall be submitted in writing by the party seeking said modification, to the other party. Said modification shall be agreed upon in writing by both parties in order for it to be enforceable. Absent said written modification, this form and said purchase order shall exclusively control the terms of the agreement between the parties.
2. Except as herein provided, no purchases ordered by unauthorized individuals shall be enforceable against B.E.D. Only individuals expressly designated as those vested with the authority to purchase on behalf of B.E.D. shall be considered persons possessing binding purchasing authority. Agreements entered into with unauthorized individuals shall be void and B.E.D. shall not be liable for any such unauthorized agreements.
3. Sellers, suppliers and contractors shall not assign, delegate, transfer, convey, sublet, or otherwise dispose of their rights, titles, interests or obligations under this contract, or their power to execute such contract to any other person, firm or corporation, without the previous written consent of B.E.D.'s Purchasing Office.
4. The parties to this agreement hereby agree that this contract is subject to the laws of the State of Vermont. The parties to this agreement further agree that Vermont's version of the Uniform Commercial Code, found in Title 9A of Vermont Statutes Annotated, shall apply.
5. B.E.D. may return any materials which are defective, unsatisfactory, or of inferior quality or workmanship, or fail to meet specifications or other requirements of this order.
6. B.E.D. reserves the right to cancel this order if goods are not shipped as directed. B.E.D. reserves the right to terminate its obligations under this order or any part hereof if any delivery/awarded service is not made in the time provided or, if no time is specified, within a reasonable time or if the material that is delivered/service provided is not as specified.
7. Seller shall ship in accordance with any instructions from B.E.D. and the requirements of common carriers to secure the lowest transportation costs. No shipments are to be made C.O.D., nor shall any such shipments be accepted. When goods or materials are shipped F.O.B. point of shipment, all freight charges are to be PREPAID by the Seller and added to the invoice total. An original copy of paid express or freight bill shall be attached to the invoice.
8. Seller shall furnish a packing slip with all shipments showing the purchase order number, seller name, catalog numbers, quantities (including back orders) and a full description of materials shipped.
9. Contractor shall furnish current Certificate of Insurance as outlined by B.E.D.'s Insurance Requirement Contractor's Order, a copy of which will be provided by B.E.D.'s Purchasing Office to the Seller. Such evidence of insurance shall be received at B.E.D. before the commencement of work, or Purchase Order and/or Contract is awarded, whichever is sooner, and such insurance shall be maintained throughout the duration of awarded contract. Seller shall be liable for any and/or all damages/claims (including but not limited to bodily/personal injury, property damage, loss of income, business interruption, or wrongful death), while performing or as a result of work assigned/related to the awarded contract.
10. The contractor shall be responsible for ensuring that all utilities are properly located, marked and identified through utilization of, and compliance with, the requirements of the "Dig Safe" program (30 V.S.A. §7001 et seq. and Vermont P.S.B. Rule 3.800). Contractor is responsible for working around existing utilities and agrees to indemnify and hold B.E.D. harmless for any damages to such utilities except for such damages whose sole proximate cause is due to negligence by B.E.D.
11. Seller shall follow all B.E.D. Safety Rules, a copy of which shall be provided, as well as follow good utility practices on details not covered in specification documents with preference given to B.E.D. Standard practices if suitable. Seller is responsible for following all applicable EPA/VOSHA/OSHA/NESC and NEC rules and regulations.
12. When the contract is awarded to provide services, the cost of service shall be a fixed fee or a time and material basis with a Not To Exceed amount. Expenses shall be billed at cost unless otherwise specified on the awarded contract. Seller shall furnish an invoice detailing Purchase Order number, scope of work, mileage and other expenses. If the contract is awarded on a time and material basis, the invoice shall also include dates worked, name of personnel, number of labor hours worked (traveled if chargeable), rate per hour and total labor, equipment rental hours and rates and materials. Seller shall be responsible to obtain all necessary permits and copies shall be furnished with each invoice. Seller shall also furnish documentation of all reimbursable expenses with each invoice.
13. Unless otherwise specified, payments shall be made on partial deliveries accepted by B.E.D. when the amount due on such deliveries so warrants. Progressive billing for services rendered shall be accepted unless fixed fee is quoted. Where there is a question of non-performance involved, payment in whole or part against which to charge back any adjustment required, shall be withheld. In the event cash discount is involved, the withholding of payment as provided herein shall not deprive B.E.D. from taking such discount.
14. In accordance with city regulations, invoices for completed purchase orders must be received by B.E.D.'s Accounts Payable by the 27th of each month to assure payment by approximately the 15th of the following month. Invoices received after that date shall be carried forward to the following month.
15. **All invoices shall be mailed to the ATTENTION of B.E.D.'s Accounts Payable.** Inquiries regarding the status of unpaid invoices shall likewise be directed to B.E.D.'s Accounts Payable.